



GRAB-N-DRIVE



GRAB-N-DRIVE
A real driving force



EXPERIENCE COMES ATTACHED

Originally starting life as a general construction plant hire and contracting business, Exac-One focused its attentions exclusively on excavator attachments in 2002.

Today, we have grown into one of the UK's leading suppliers of excavator attachments, offering an extensive product range.

Key to this outstanding success and exceptional growth has been the company's willingness to innovate along the way. Though we source attachments from all over the world, we work in close partnership with our clients and suppliers, customising tools to suit the UK market, carrying out improvements and modifications to meet our customers' most specific requirements.

Calling upon a vast pool of relevant attachment experience and expertise gained over many years, we are able to provide you with all the information they need to make an informed purchasing decision.

This is the simple philosophy at the very heart of Exac-One. Applying unrivalled practical experience and specialist knowledge to shape the attachment solution that best suits your needs.





POST DRIVING - SAFELY

Take the backache out of fencing. Let the Grab-n-Drive system do all of the hard work so you don't have to!

Grab-n-Drive is designed to work on standard excavators. It connects to the excavator in the same way that a conventional bucket does and operates off the auxiliary hydraulic circuit which is standard on most compact excavators.

Operation of the hammer and grab functions is achieved via the optional diverter valve kit which can easily be installed on the excavator in a matter of minutes – it's a 'plug and play' system! If the excavator has two auxiliary circuits, the diverter valve kit won't necessarily be required.



MANUFACTURING CAPABILITY COMES ATTACHED



Right from the very outset, Exac-One has always had an understanding of the full potential of an excavator. A clear vision that it could be so much more than just a digger.

Driven by a growing customer demand, from day one we were exploring how to make the excavator a tool carrier. Designing and building attachments to address very specific problems for clients. Making the most of our in-house technical expertise to resolve design, manufacturing and product application issues.

	GD10S	GD20S	GD30S	GD40S
Carrier weight (t)	1.8 - 3	2.5 - 5	4.5 - 9	7.5 - 14
Weight (kg)	195	340	390	585
Oil Flow (l/m)	14 -30	25 - 40	30 - 45	45 - 65
Oil Pressure (bar)	120	90	110	110
Impact Rate (bpm)	650 - 1100	650 - 1150	700 - 1250	550 - 1200
Impact Energy (joules)	240	340	610	810
Tool Diameter (mm)	40	45	53	65
Dim "A" (mm)	1180	1180	1300	1450
Dim "B" (mm)	920	940	990	1080
Dim "C" (mm)	1250	1250	1390	1390
Dim "D" (mm)	660	660	730	730
Dim "E" (mm)	80	80	90	90
Dim "F" (mm)	310	350	360	400

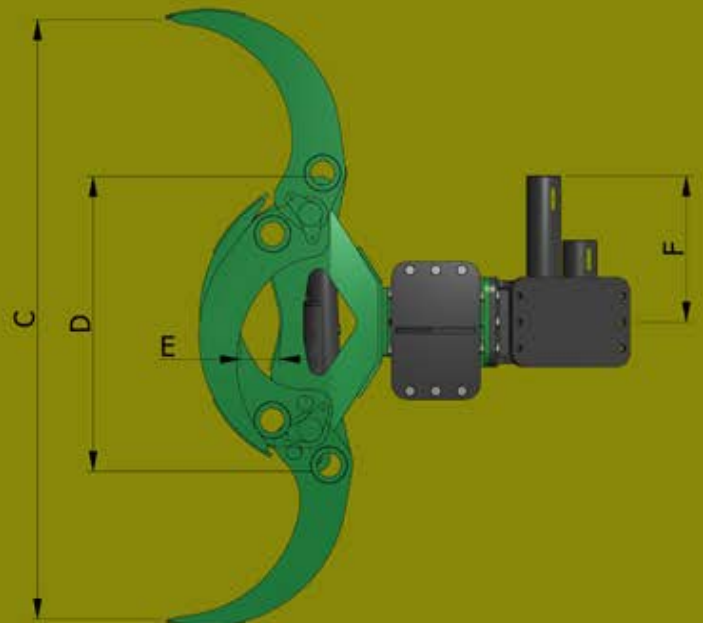
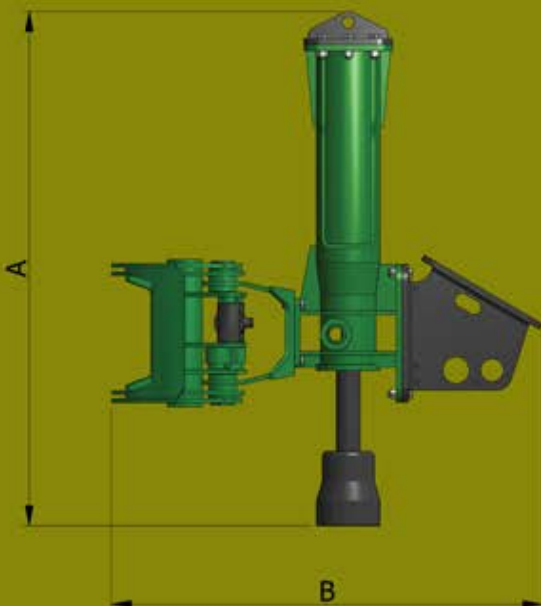

GRAB-N-DRIVE

POST DRIVING MADE EASY

Designed as a 'plug and play' excavator attachment the Exac-One Grab-n-Drive makes post driving simple and safe. Exac-One was tasked with designing and manufacturing a range of post drivers which improve safety in the field by removing the man from the working end of the excavator.

The Grab-n-Drive system combines the power, performance and safety of a hydraulic hammer with the handling capabilities of a timber grab and, with the added benefits of compact dimensions and light weight.

The grab is used to handle single or multiple posts as part of the fencing process. It is then used to select and position individual posts before being driven into the ground by the hammer. The hammer delivers around one thousand blows per minute giving exceptional driving speed and as there are no exposed moving parts, optimum safety is guaranteed.

The Grab-n-Drive system is supplied as standard with two tools: - a chisel for breaking up stone, concrete or asphalt and a tapered post driving tool. Stowage positions for two spare tools are incorporated into the Grab-n-Drive body. The unique design of the tapered driving tool ensures that the post is always centralised for maximum driving efficiency and minimum wear and tear on the hammer. Other tool options are available including 'blunt end rock spike' for creating guide holes in difficult ground, cup type tools for different sized posts, and flat pad tools with screw in studs for irregular shaped posts. Tool changing is simple and safe and can be done in a matter of minutes.

Tilt options are also available for the Grab-n-Drive system which can be advantageous, but not essential, on sloping ground.

A common problem associated with post driving is ensuring that the posts are vertical and that they are driven to a uniform depth. The Grab-n-Drive incorporates a simple chain system which gives the operator visual reference of verticality and depth.

An advantage of the Grab-n-Drive system over conventional post drivers is that the whole device is above the fence line making it the perfect tool for driving intermediate posts on post and rail fencing and for maintenance work on existing fences. Another advantage is the ability to drive long posts and piles - the only limitation being the working height of the excavator.



GRAB-N-DRIVE

A REAL DRIVING FORCE

GRAB-N-DRIVE
SIMPLE AND SAFE POST DRIVING

Compact and light weight.

Tool options for different applications.

Visual reference system for verticality
and depth.

Spare tool stowage.

Tilt options.



Exac-One Ltd

The Mount Buildings

Tunnel Hill

Upton on Severn

Worcestershire

UK

WR8 0QL

+44 (0)1684 593052

www.exac-one.co.uk
info@exac-one.co.uk